



Modular Cooking Range Line 700XP Half Module Gas PowerGrill Top

ITEM # _____

MODEL # _____

NAME # _____

SIS # _____

AIA # _____



371042 (E7GRGDGC0P)

* NOT TRANSLATED *

Main Features

- Unit to be mounted on open base cupboards, bridging supports or cantilever systems.
- Stainless steel burners with flame failure device, optimized combustion and protected pilot light.
- AISI 441 stainless steel deflective shields located below the radiants prevent burners from clogging, minimize flare ups and ensure even heat distribution (PATENT PENDING).
- Dishwasher-safe radiants removable without the use of tools to facilitate cleaning.
- Extractable full-depth grease collection drawer to accumulate excess grease and oil.
- Stainless steel high splash guards on the rear and sides of cooking surface. Splash guards can be easily removed for cleaning and are dishwasher-safe.
- Cooking grids made in highly resistant enameled cast iron for easy cleaning.
- Suitable for countertop installation.

Construction

- All exterior panels in Stainless Steel with Scotch Brite finishing.
- One piece pressed 1.5 mm work top in Stainless steel.
- Model has right-angled side edges to allow flush fitting joints between units, eliminating gaps and possible dirt traps.
- IPX4 water resistance certification.

APPROVAL: _____



Experience the Excellence
www.electroluxprofessional.com

Optional Accessories

• Junction sealing kit	PNC 206086	<input type="checkbox"/>
• Draught diverter	PNC 206126	<input type="checkbox"/>
• Matching ring for flue condenser	PNC 206127	<input type="checkbox"/>
• Support for bridge type system, 800mm	PNC 206137	<input type="checkbox"/>
• Support for bridge type system, 1000mm	PNC 206138	<input type="checkbox"/>
• Support for bridge type system, 1200mm	PNC 206139	<input type="checkbox"/>
• Support for bridge type system, 1600mm	PNC 206141	<input type="checkbox"/>
• Support for bridge type system, 400mm	PNC 206154	<input type="checkbox"/>
• Chimney upstand, 400mm	PNC 206303	<input type="checkbox"/>
• Right and left side handrails	PNC 206307	<input type="checkbox"/>
• BACK HANDRAIL 800 MM - MARINE	PNC 206308	<input type="checkbox"/>
• Flue condenser for 1/2 module, 120 mm diameter	PNC 206310	<input type="checkbox"/>
• Scraper kit with hooks for HP grills	PNC 206347	<input type="checkbox"/>
• Base support for feet or wheels - 400mm (700/900XP)	PNC 206366	<input type="checkbox"/>
• - NOT TRANSLATED -	PNC 206462	<input type="checkbox"/>
• Frontal handrail 400mm	PNC 216046	<input type="checkbox"/>
• Frontal handrail 800mm	PNC 216047	<input type="checkbox"/>
• Frontal handrail 1200mm	PNC 216049	<input type="checkbox"/>
• Frontal handrail 1600mm	PNC 216050	<input type="checkbox"/>
• Large handrail - portioning shelf, 400mm	PNC 216185	<input type="checkbox"/>
• Large handrail - portioning shelf, 800mm	PNC 216186	<input type="checkbox"/>
• 2 side covering panels for top appliances	PNC 216277	<input type="checkbox"/>
• Pressure regulator for gas units	PNC 927225	<input type="checkbox"/>

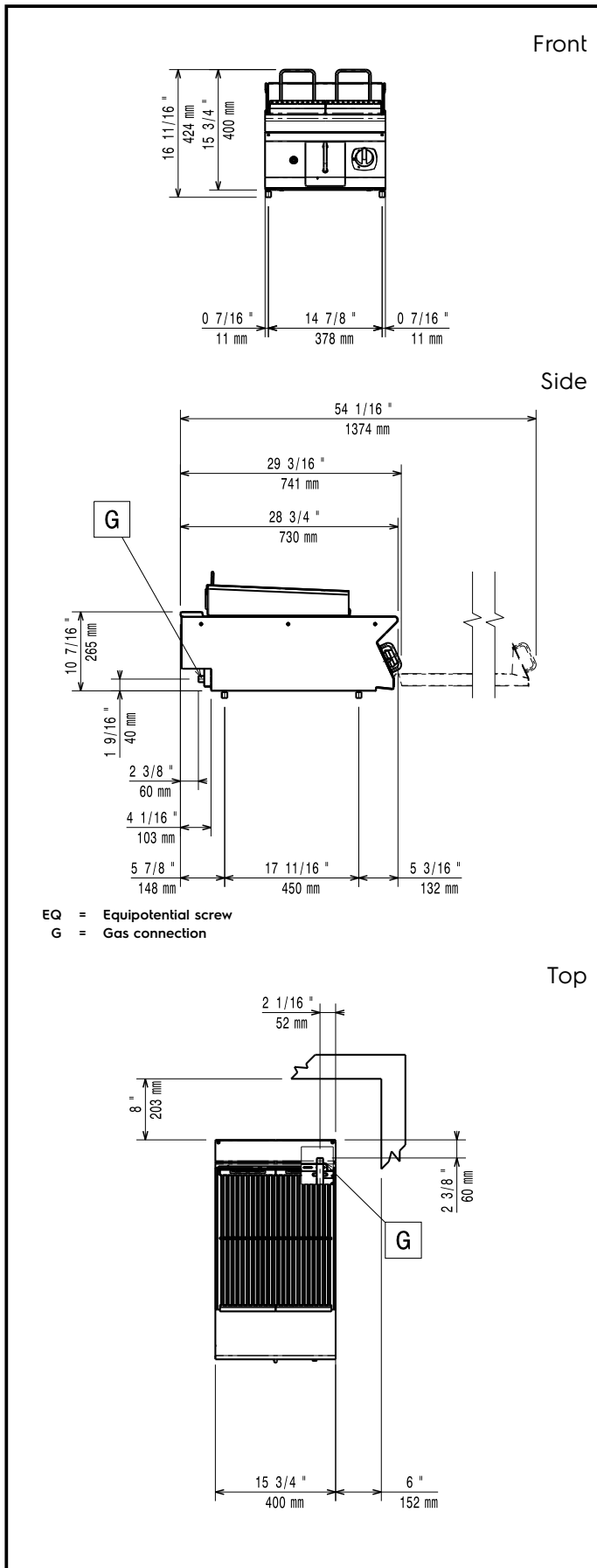

Gas

Gas Power:	7 kW
Standard gas delivery:	Natural Gas G20 (20mbar)
Gas Type Option:	
Gas Inlet:	1/2"

Key Information:

If appliance is set up or next to or against temperature sensitive furniture or similar, a safety gap of approximately 150 mm should be maintained or some form of heat insulation fitted.

Net weight:	32 kg
Shipping weight:	50 kg
Shipping height:	580 mm
Shipping width:	460 mm
Shipping depth:	820 mm
Shipping volume:	0.22 m ³
Certification group:	N7EGG
Cooking surface width:	371 mm
Cooking surface depth:	472 mm